

Measuring Wind Turbine Reliability - Results of the Reliawind Project

Michael Wilkinson

GL Garrad Hassan, St Vincent's Works, Silverthorne Lane, Bristol BS2 0QD, UK

+44 117 972 9900

michael.wilkinson@gl-garradhassan.com

Keir Harman

GL Garrad Hassan, UK

keir.harman@gl-garradhassan.com

Fabio Spinato

GL Garrad Hassan, UK

fabio.spinato@gl-garradhassan.com

Ben Hendriks

GL Garrad Hassan, Netherlands

ben.hendriks@gl-garradhassan.com

Thomas van Delft

GL Garrad, UK

Thomas.vandelft@gl-garradhassan.com

Abstract

The aim of the EU FP7 Reliawind project was to identify and understand critical failures and their mechanisms through quantitative studies of detailed wind farm data. A common wind turbine taxonomy and a universal database structure for storing downtime events from multiple manufacturer's turbines have been defined. Systematic and consistent processes have been developed to deal with historical data from wind farm Owners and Operators. Data including 10-minute SCADA, service records/work orders and alarm logs have been analysed to determine downtime events within the common taxonomy. Around 35,000 downtime events have been identified, tagged within the taxonomy and added to the common database structure. The downtime events have been analysed to determine the distribution of failure rates and downtimes between the sub-assemblies.

1 Introduction

A number of quantitative studies of wind turbine reliability have been carried out in the last 10 years. The Dutch research programme DOWEC, which has been among the pioneers of the quantification of wind turbine reliability figures, has presented some interesting studies [1]-[5]. Further reliability analyses have used data from existing commercial and public databases. Relevant results have been achieved by research carried out by various authors [6]-[9]. The objectives of these studies were to extract information from the field to understand wind turbine reliability from a statistical point of view and provide a benchmark for further analysis.

The Reliawind project is a European Union 7th Framework Integrated Project, with an overall budget of €7.7M, involving 10 industrial and academic partners. Reliawind has the aim of identifying, quantifying and understanding critical failures and their mechanisms. The results are being used to compare the reliability of operational turbines and ultimately to improve machine reliability through design for reliability and targeted condition monitoring.

The first stage of this work has been a field study to measure the reliability of existing wind turbines at several operational wind farms. As part of this study, wind farm Owners and Operators have provided historical data including 10-minute SCADA data, automated alarm-logs and service records / work orders from operational wind farms representative of those currently installed. These sources are discrete and often of varying quality, but the authors have developed systematic and consistent processes to connect these data. A significant amount of detailed data has also been provided from the wind turbine manufacturers who are part of the Reliawind Consortium.

The success of reliability analysis relies on the specification and rigorous application of consistent structures and processes. The Reliawind Consortium has developed a standard wind turbine taxonomy, which assigns each part to a subassembly, assembly and subsystem. A standard database format with a number of tables has also been developed, which holds information about all downtime events at each wind turbine. Events identified in the field study with a downtime greater than 1 hour and requiring at least a manual restart

have been assigned to the relevant subassembly or part where possible. The result is a consistently populated database that allows quantitative results to be derived and comparisons made.

The database can be queried to extract the Time to Failure for each subassembly, which can be used to derive Reliability Profiles showing downtime and failure rate for each subassembly. The Reliability Profiles are of benefit to Owners and Operators as they allow the comparison of their machines against a generic wind turbine from the whole database. As more data is added, more detailed comparisons can be made, such as comparing the reliability of machines by turbulence intensity or other site conditions. For wind farms approaching the end of the manufacturer's warranty, the Reliability Profiles can aid the Owner's decision making for future operation and maintenance strategies and expected costs.

The methodology and results of the field study will be presented and the benefits of the Reliability Profile metrics will be described.

2 Methodology

The Reliawind field study has been conducted to measure the reliability of operational wind turbines representative of modern technology.

2.1 Wind Farm Selection Criteria

It was necessary to impose common wind farm selection conditions to ensure results from each source are comparable and of relevance to the wider Reliawind project. These conditions are:

- Site – should comprise at least 15 turbines; and
- Turbines – should have been running for at least two years since commissioning.

Additionally, it was agreed that only modern turbines representative of standard technology should be included, leading to the imposition of the conditions that the turbines should be:

- Variable speed, pitch regulated; and
- Rated at > 850 kW.

It is important to note, however, that in principle, subject to there being appropriate data available, this analysis can be performed for any wind turbines.

2.2 Data Available from a Wind Farm

In general, modern wind farms have the following information available:

- 10-Minute average SCADA data;
- Fault / alarm logs;
- Work orders / service reports; and
- O&M contractor reports.

These sources are discrete and are not designed to easily allow reliability information to be extracted; a substantial effort has been invested in connecting these sources. Data for this study have been provided by wind turbine manufacturers who are members of the Reliawind consortium and wind farm Owners and Operators who are members of the Reliawind Users' Working Group.

2.3 Turbine Taxonomy

It is understood that various attempts at classifying turbines components have been made in the past and various standards exist e.g. the RDS-PP classification for power plants [10]. However, for reasons of practicality, and in particular the necessity to find a structure that could conveniently be applied to the turbines selected for the field study, it was decided that a new Reliawind taxonomy be developed. This is based on the terminology of System, Sub-System, Assembly, Sub-Assembly and Component/part. Examples of this terminology are as follows:

A taxonomy of this type may be constructed on a functional or positional basis. The Reliawind taxonomy is a hybrid approach, with a positional grouping for mechanical components and a functional grouping for electrical elements. This reflects the fact that electrical energy may generally be transmitted between positional elements such as between the nacelle and base of the tower, whereas mechanical energy is generally confined within positional elements. A recommendation from this work is that standardisation should be pursued to provide a definition of a taxonomy that would permit reliability data

from different studies to be more easily compared.

2.4 Algorithms and Tools

The diverse data sets available from wind farms of different manufacturers are described above. Extensive efforts have been devoted to cleaning and linking these data and it has been found that methods needed are strongly dependant on the type of manufacturer's SCADA system. However, the general approach is outlined as follows:

10-minute SCADA data are used to determine whether the turbines are available in any particular 10-minute period. A combination of turbine time counters, power and wind speed signals are used, depending on the configuration of the SCADA system. This allows the basics of the downtime events to be identified.

The alarm logs are interrogated to refine the start and end times of the downtime events. The various alarm log entries falling within the downtime event are then gathered together. It has generally been found that this information may not always indicate the real cause of downtime, rather subsequent errors resulting from the shutdown may be dominant.

The service records are then linked to the downtime events, followed any site operator's monthly reports.

A database interface tool has been developed to present all the information associated with each downtime event to an engineer or analyst, who can then make a judgement on which part of the turbine was responsible for the downtime and allocate this within the standard taxonomy described above.

2.5 Reliability Database

To permit data to be aggregated and for data from different partners to be compared in a meaningful fashion, it was agreed to work to a common approach for storing and processing these data. A set of 5 tables was developed, which allow data to be stored and compared in standard form:

- **Table 1 Events** A list of all fault events;
- **Table 2 Failure Rates** Failure rates (failures/year) by subassembly;
- **Table 3 Downtime** Number of hours by subassembly;
- **Table 4 Wind Farm Configuration** A description of the wind farms in the above tables; and
- **Table 5 Additional Turbine Information** Containing wind farm production and other lifetime related quantities.

This list of events in Table 1 is exhaustive within the following criteria:

- The event required manual intervention to restart the machine; and
- The event resulted in downtime ≥ 1 hour.

There are no missing events or missing time periods; or if there are, the missing time periods will be noted and the reasons stated. An example of data formatted into these requirements is given in Figure 2 and around 35,000 downtime events have been added to the database. Note that not all entries have a complete field list; this is because the detailed information required is not always available for every downtime event.

Each downtime event is also tagged with a maintenance category, which is a description of the maintenance impact of the fault, ranging from 1 to 4 with 1 being the least severe (manual restart) and 4 being the most significant (major replacement).

2.6 Reliability Analysis

Having been applied with the cleaning and sorting processes described above, the data are analysed using standard reliability methods. Such methods include a Pareto analysis for the average failure rate, which is an ordered visual representation of the failure rate value i.e. the WT parts or sub-assemblies have been sorted by failure rate, as it results from the calculation.

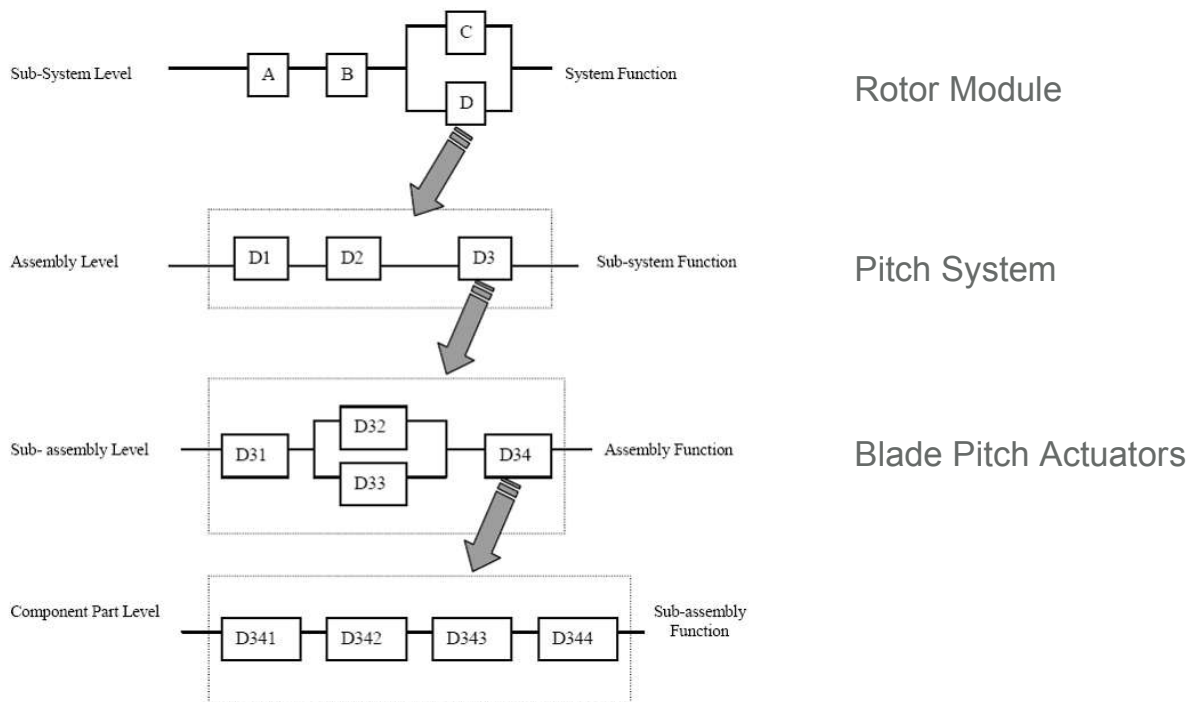

Figure 1. Example from the Reliawind turbine taxonomy.

TABLE 1 EVENTS

Wind Farm	Turbine ID	Date & Time of Event	Time to Repair TTR (hours)	Actual Repair Time ART (hours)	Sub-System	Assembly	Sub-Assembly	Part	Failure Mode	Root Cause	Maintenance Category	Severity Category	Additional information
A	1	2008-04-01 11:28:01	54.2	N/A	Drive train	Gearbox assembly	Gearbox	N/A	N/A	N/A	4	3	N/A
A	23	2008-04-24 01:56:11	168.4	3.5	Rotor	Pitch system	N/A	N/A	N/A	N/A	3	2	N/A
B	2	2008-04-25 08:43:24	2.5	1	Power	Generator assembly	Generator	Stator phase b winding	Open	Over current	1	1	Series defect
...

Figure 2. Example downtime events.

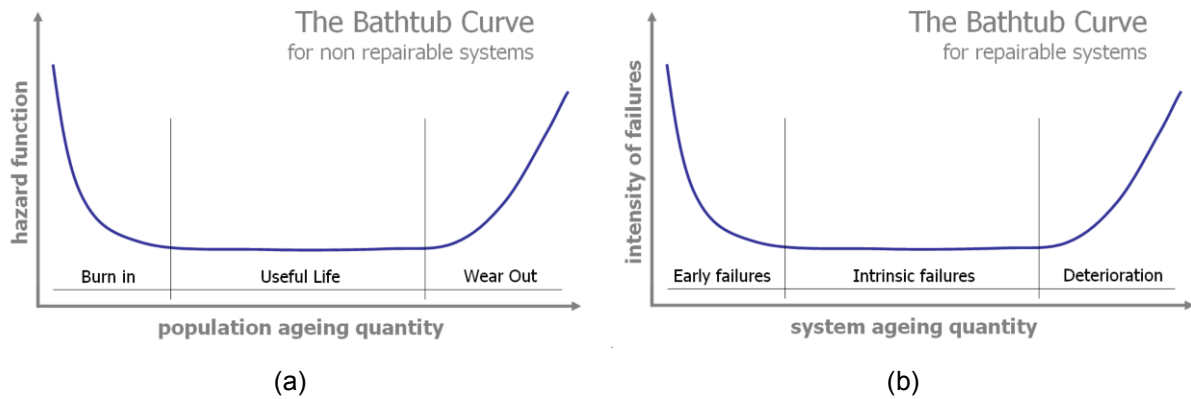

Figure 3: The bathtub curve (a) for non-repairable systems and (b) for repairable systems [8].

The average failure rate for sub-assemblies has been calculated over the entire recording period according to:

$$\lambda = \frac{\sum_i n_i}{T - \sum_k D_k} \quad (1)$$

where

- i = index counting the number of sub-assemblies failures
- n = number of sub-assembly failures
- T = total length of the recording period
- k = index counting the total number of downtimes
- D = downtime

Some of the sub-assemblies analysed present an insufficient number of failures for a rigorous analysis, therefore a minimum of 5 failures has been adopted, although results have been critically evaluated for lower number of failures.

3 Results

3.1 Reliability Profiles

To date around 350 wind turbines have been added to the database, comprising around operating for varying lengths of time. The downtime events from these turbines have been analysed by the methods described above and can be investigated in many ways such as:

- Matching the failure data with external conditions such as low

The calculation of the average failure rate implies that the sub-assemblies are either perfectly repaired or made of non-repairable components that are replaced at any action. In reliability terms this is equivalent of assuming the sub-assembly reliabilities lie in the constant, flat part of the bathtub curve. The bathtub curve represents the hazard function of a population and is constant when the related reliability is modelled by the exponential function, see Figure 3 (a).

It must be noted that in this case the bathtub curve models the intensity function of a Poisson Process rather than the hazard function related to a certain distribution. In practical terms this mathematical difference results in considering the failures of the repairable population related to one another rather than independent.

- temperatures, extreme gusts, wind direction, location in the farm, etc.
- Determining the failure rate of different severities of fault such manual restart, major replacement, etc. For example, manual restarts are much more critical offshore than they are onshore.
- Evaluating the number of failures in time: does this confirm the assumption of a Poisson Process confirmed or not?
- Investigating the sequence of failures, investigating the sequence of changes in the external conditions and failures (e.g. failures occurring soon after a grid failure, or after a cold start).
- Evaluating the distribution of fault statistics over the population.

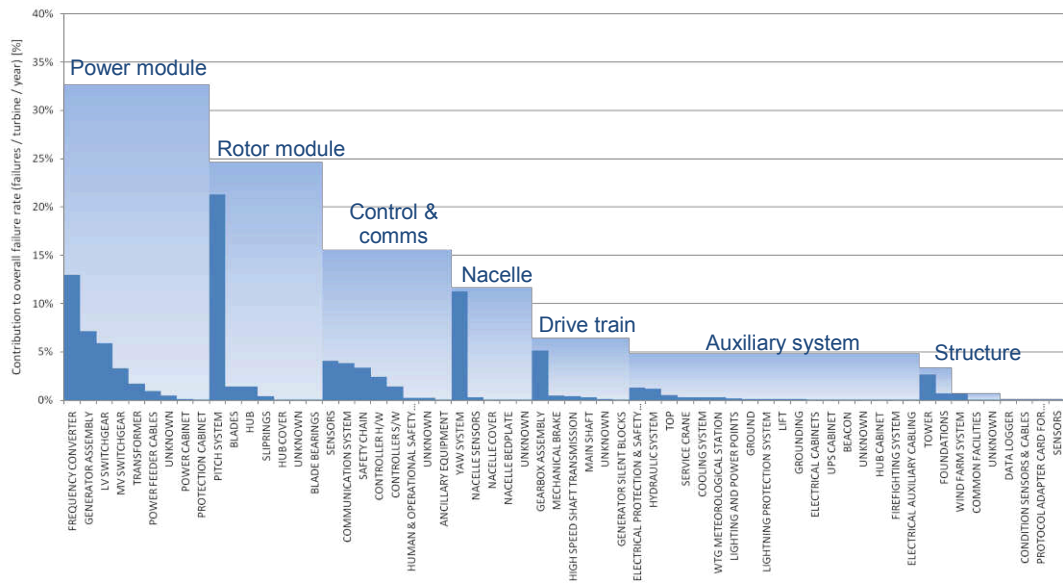

Figure 4. Normalised failure rate of sub-systems and assemblies for turbines of multiple manufacturers in the database.

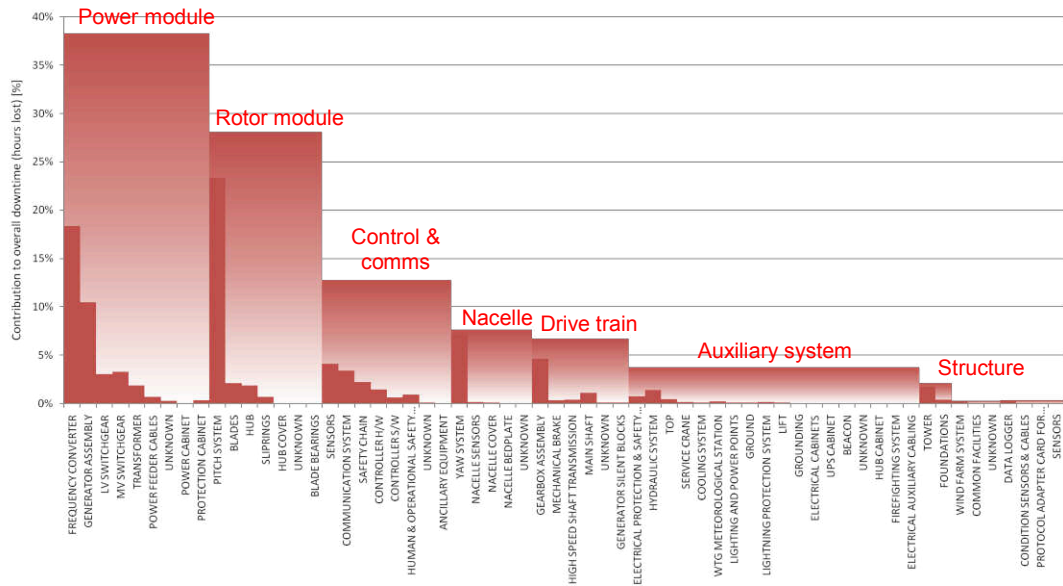

Figure 5. Normalised hours lost per turbine per year to faults in sub-systems and assemblies for turbines of multiple manufacturers in the database.

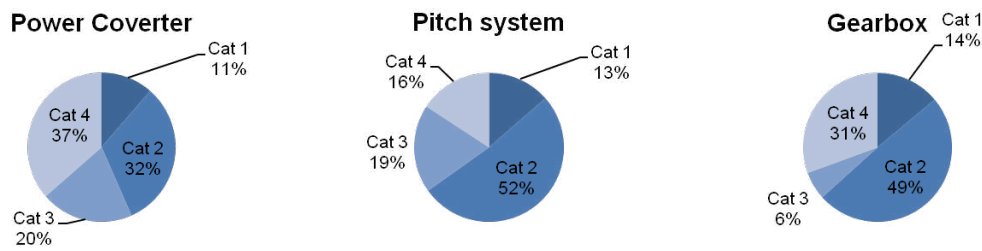

Figure 6. Composition by Maintenance Category of significant assemblies.

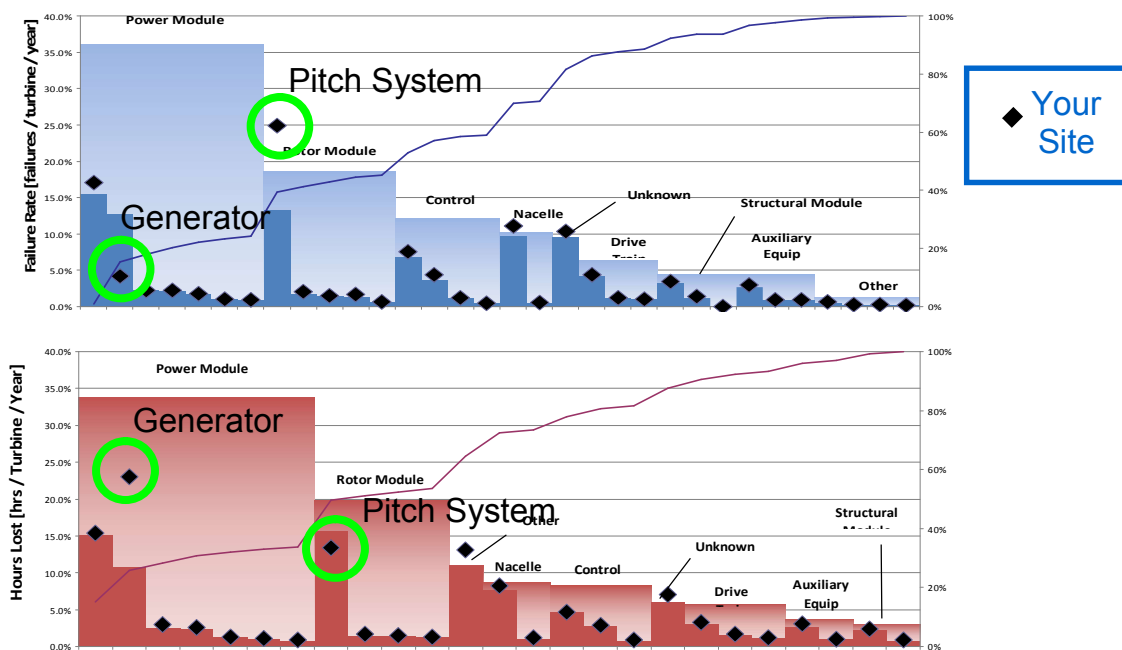

Figure 7. Example demonstration of the use of the reliability profiles for benchmarking a wind farm's reliability (note: not real site data).

Many of these aspects have been addressed, for example the charts in Figure 4 and Figure 5 highlight the failure rates and downtimes on a per sub-system and per assembly basis. All downtime events have been included in these charts (i.e. manual restarts have been included). The data presented here are normalised relative to the overall failure rate / downtime, to show the percentage contribution to the overall failure rate / downtime. The large background blocks show sub-systems, the smaller foreground blocks show assemblies.

These results contain much information, for example, it can be seen from the failure rate chart that 50% of the contribution to overall failure rate stems from the power and rotor modules, with the most significant

contributors being the frequency converter, generator and pitch system.

The authors have found that generally the data recorded at operational wind farms do not generally permit the determination of the root cause of the downtime and the results of Figure 4 and Figure 5 show the replaced component. It is noted that the "unknown" category can be significant, but this is to be expected given the source data and reflects experience of analysis of public surveys such as reported by Spinato et al. [9].

As mentioned above, Figure 4 and Figure 5 contain all downtime events tagged within the taxonomy from all maintenance categories. It is possible to look in more detail at the composition of each assembly

and Figure 6 shows this breakdown for three significant assemblies.

3.2 Wind Farm Benchmarking

The use of the reliability profiling and analysis demonstrated above is clear for a wind farm Owner or Operator. This analysis can be undertaken for a single wind farm or for a portfolio of wind farms. The results may then be plotted against the wider population as demonstrated in Figure 7. For this particular example wind farm it can be seen that the failure rate of the generator is below the wider population, but the corresponding downtime is significantly higher. Conversely, the failure rate of the pitch system is higher the rest of the population, but the resulting downtime is not significant. The wind farm Owner or Operator may then use this information to guide on-going maintenance or end of warranty decisions.

4 Conclusions

The Reliawind project intended to address the need for a quantitative measurement, understanding and improvement of turbine reliability. The first part of this work was the field study, which has analysed data from around 350 wind turbines from multiple manufacturers. The following achievements have been made:

- A common wind turbine taxonomy to describe the allocation of parts of the turbine has been defined;
- A database structure for storing downtime events from multiple manufacturer's turbines has been defined;
- 10-minute SCADA, service records / work orders and alarm logs have been analysed to determine downtime events within the common taxonomy;
- Around 35,000 downtime events have been added to the common database structure;
- The downtime events have been analysed to determine the distribution of failure rates and downtimes between the sub-assemblies;
- The distribution of failures in the different Maintenance Categories has been investigated.

Acknowledgements

This work was funded by the EU FP7 Project RELIAWIND 212966, <http://www.reliawind.eu/>

References

- [1] Ribrant, J. & Bertling, L. M., *Survey of Failures in Wind Power Systems with Focus on Swedish Wind Power Plants During 1997-2005*, IEEE Transactions on Energy Conversion, 2007, Vol. 22, Iss. 1.
- [2] Various Authors, *Estimation of Turbine Reliability Figures within the DOWEC Project*, Technical Report 10048/4, Dutch Offshore Wind Energy Converter (DOWEC), 2002.
- [3] van Bussel, G.J.W. & Schontag, Chr., *Operation and Maintenance Aspects of Large Offshore Wind Farms*. In proceedings of the 1997 European Wind Energy Conference, Dublin, Ireland, 1997. pp. 272-279.
- [4] van Bussel, G.J.W. & Zaaijer, M.B., *DOWEC Concept Study, Reliability, Availability and Maintenance Aspects*. In Proc. of the Marine Renewable Energy Conference (MAREC), Newcastle, UK, 2001.
- [5] Various Authors, *Wind Energy Report Deutschland*, Technical Report, Insitut fur Solare Energieversorgungstechnik (ISET), Kassel, Germany, 2006.
- [6] Harman, K., Walker, E.R. & Wilkinson, M.R., *Availability Trends Observed at Operational Wind Farms*, European Wind Energy Conference, April 2008, Brussels.
- [7] Tavner, P. J., Xiang, J., Spinato, F., *Reliability Analysis for Wind Turbines*, Wind Energy 2007 Vol. 10, pp. 1-18.
- [8] Spinato, F., *The Reliability of Wind Turbines*, PhD Thesis, Durham University, UK, December 2008.
- [9] Spinato, F., Tavner, P. J., van Bussel, G. J .W & Koutoulakos, E., *Reliability of Wind Turbine Subassemblies*, IET Renewable Power Generation 2009 Vol. 3, Iss. 4, pp. 387-401.
- [10] VGB PowerTech, *Reference Designation System for Power Plants: Application Explanations for Wind Power Plants*, VGB PowerTech Guideline, First Edition 2007.
- [11] Goldberg, H., *Extending the Limits of Reliability Theory*. John Wiley & Sons, New York, 1981.